

LOW COST SEISMIC ISOLATION APPLICABLE TO DEVELOPING COUNTRIES

Engr. Najib AHMAD

Engr. Umar Qureshi

Disaster Research Institute

Preston University

&

DESIGNMEN

1.0 INTRODUCTION

Base Isolation is the process to isolate the base from the structure, so that the forces acting on the base cannot travel to the super structure.

TWO CASES

1. In which the support (base) experiences motion as a result of earthquake.
2. In which support experience motion/forces created by the operation of machinery,

2.0 REVIEW OF LITERATURE

we are primarily concerned with the effect of lateral forces created due to an earthquake, which have to be mitigated to increase the stability and performance of the structure during a seismic event.

In base isolated building, an appropriate system is constructed between the structure and its foundation. Research has shown that a well designed base isolation system improves the performance of a structure rather than without base isolation.

In its true sense isolation of a motion applies the reduction of the stresses and deflections of members, whereas supports experience motion resulting because of the seismic event.

2.2 Types of Available Isolation Systems

A. Roller type

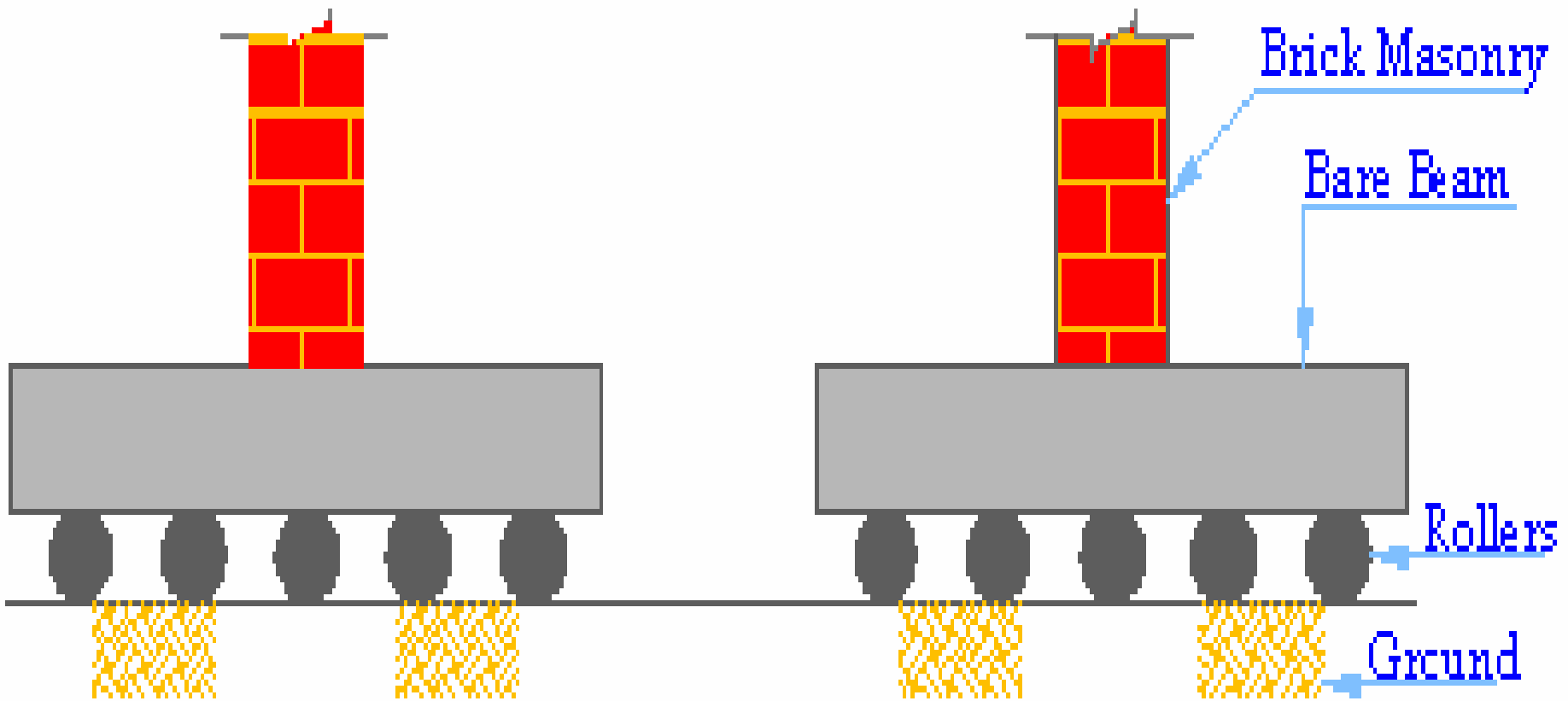

B. Sliding type

- B.1 Using stainless plates and mica etc.

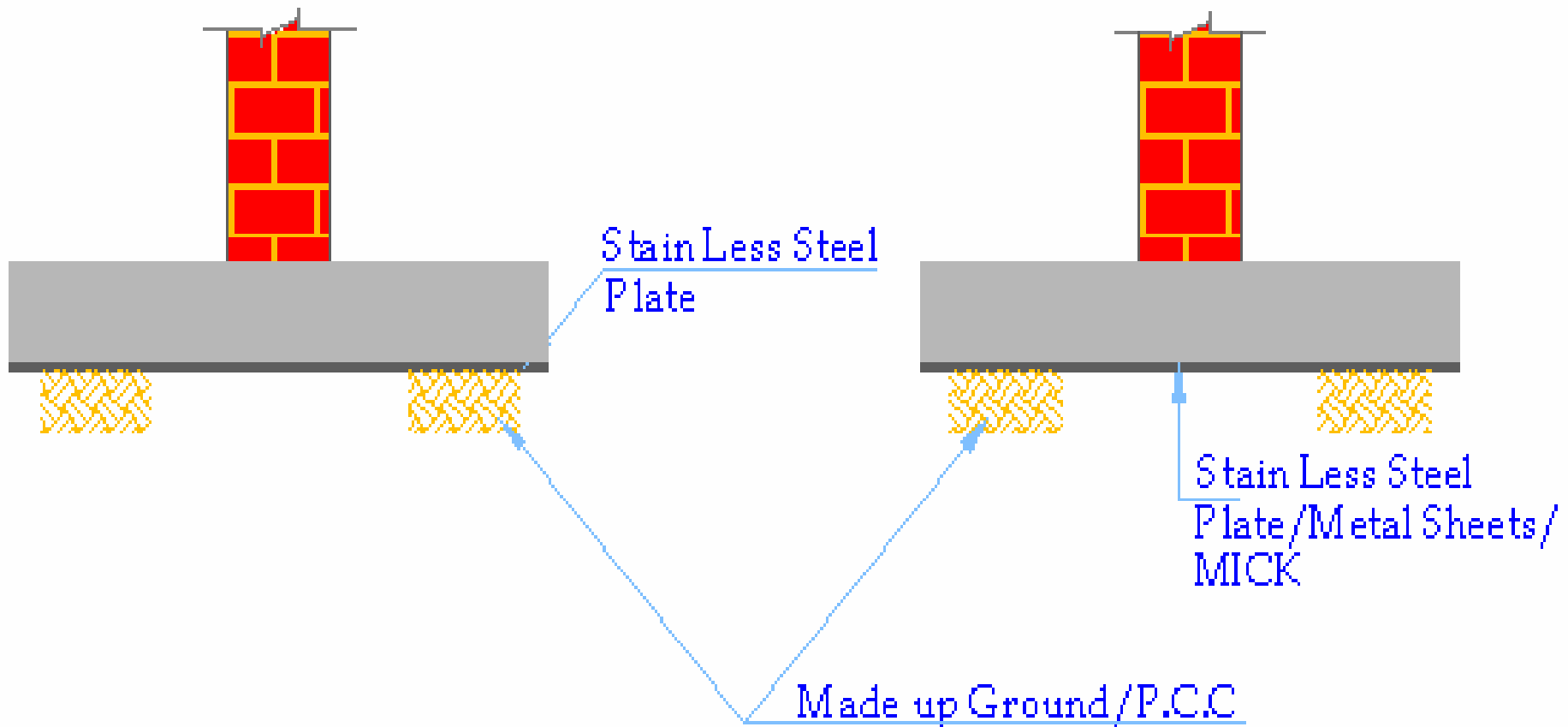

- B.2 Using Rubber pad etc.

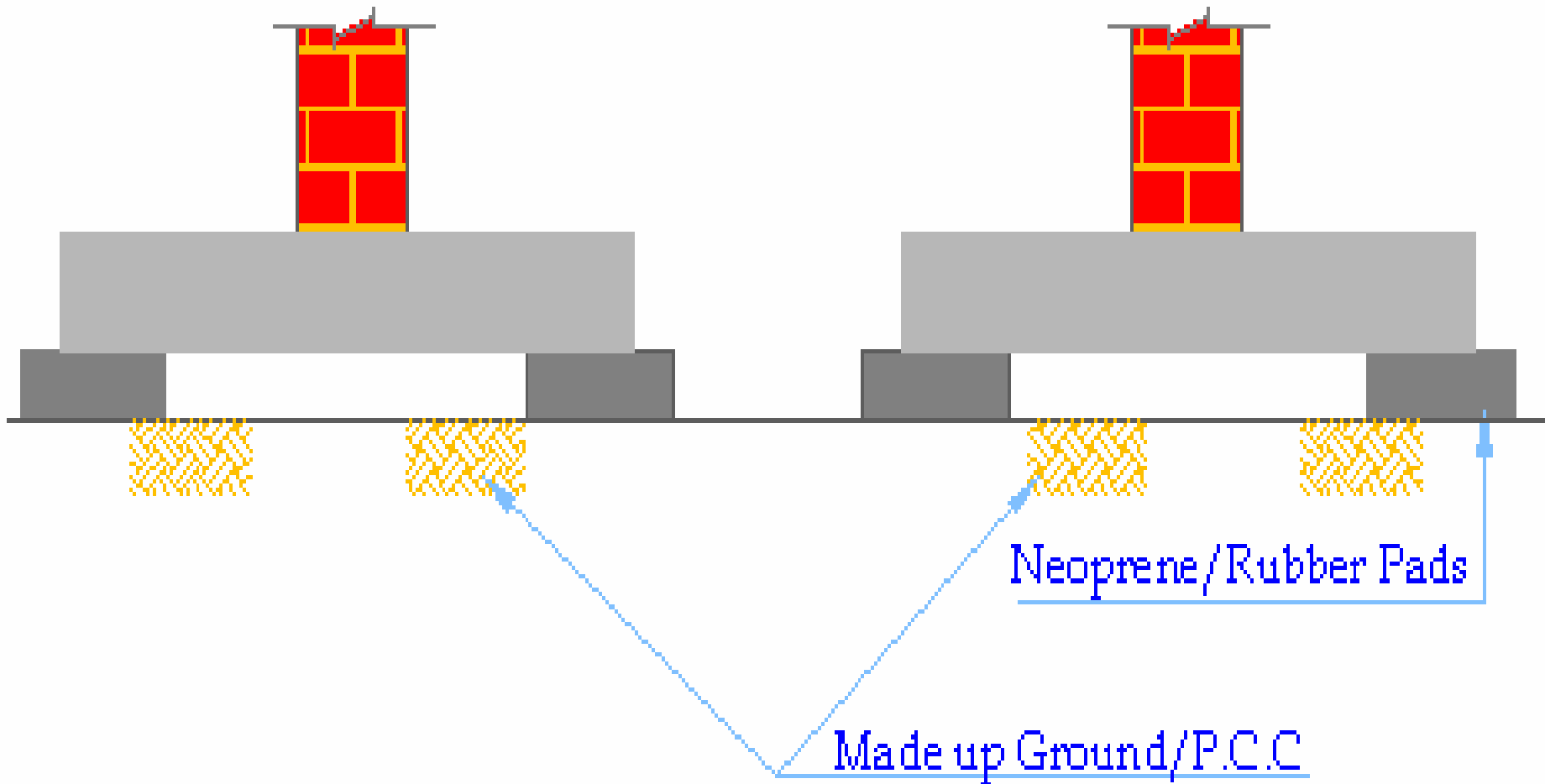

- B.3 Using Sand

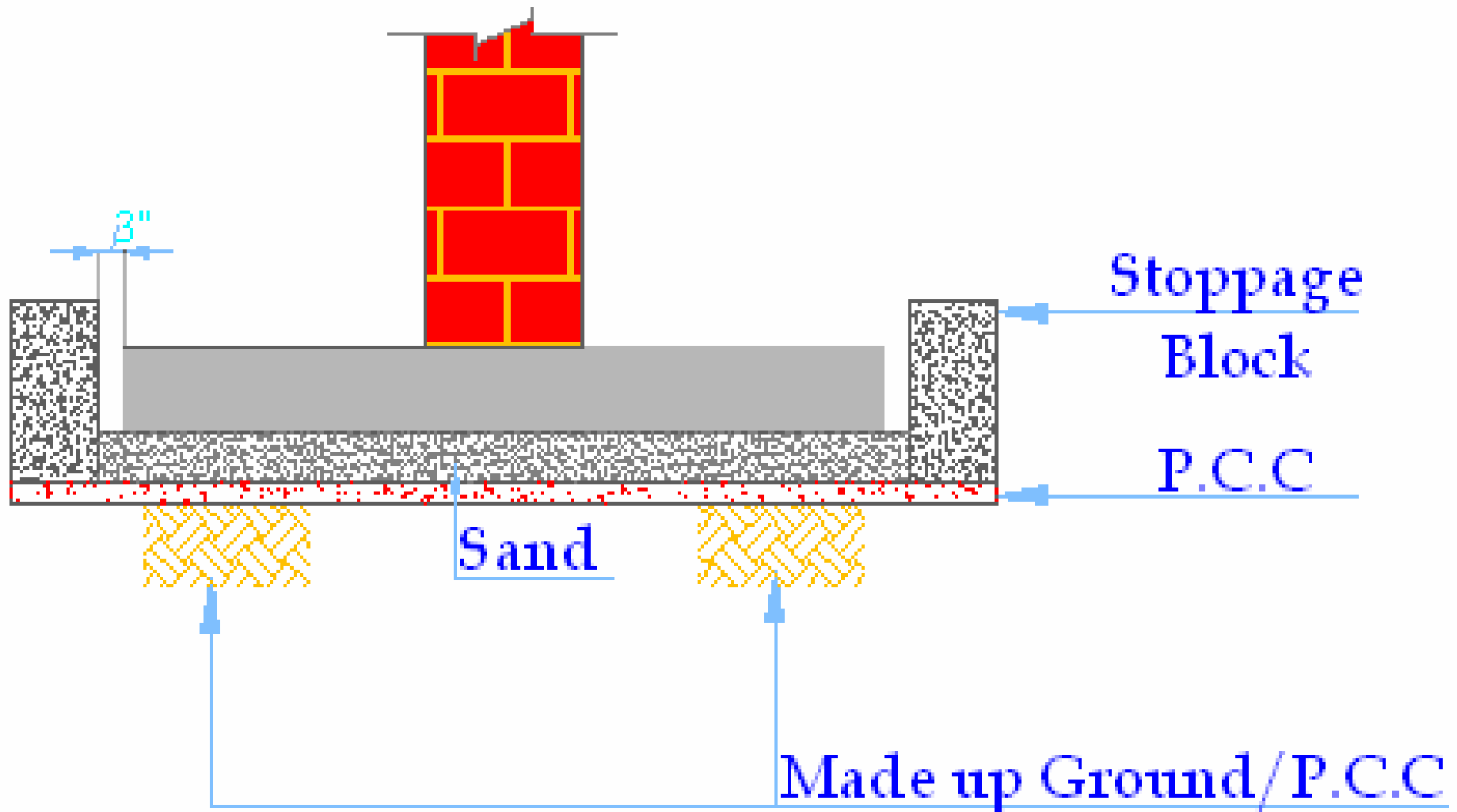

C. Pin-Connection Type

D. High-Tech Base isolation and dampers.

CONCLUSION

In each of these types there have some advantages and dis-advantages also. Some types are applicable only to wooden structures while some others are for concrete. For masonry structure there is little descriptive research done for providing a low cost solution, as is the case in our research, where we have to find and study in detail a Low cost seismic Isolation applicable to Developing countries.

2.3 WORK PLAN TO ACHIEVE OBJECTIVE

The methodology adopted for this research is to firstly propose a low cost solution for the brick masonry structures and then carryout experiments on shaking table. These tests are proposed to be carried out in Earthquake Research Centre, UET, Peshawar, on a scale model of 1:2 to 1:4. The model shall be built at site or in DRI Preston University. The performance of the final proposed system then can be verified and reviewed after the results are obtained on the shaking table.

0.3 PROPOSED LOW COST ISOLATION SYSTEM

The proposed low cost Isolation system is shown in Figures with its various aspects. This system is proposed to be based on Neoprene bearing pads or STP (low cost Scrap Tire Pad) and sand with specially build RCC components in a Masonry house. The Neoprene pad can be replaced to behave in a similar manner as proved by Dr. Ahmed Turer (METU, Turkey).

- Resistance to movement or slippage.
- ` Cost not more than 15% of the total cost of the house





0.4 INTRODUCTION TO THE TEST MODEL

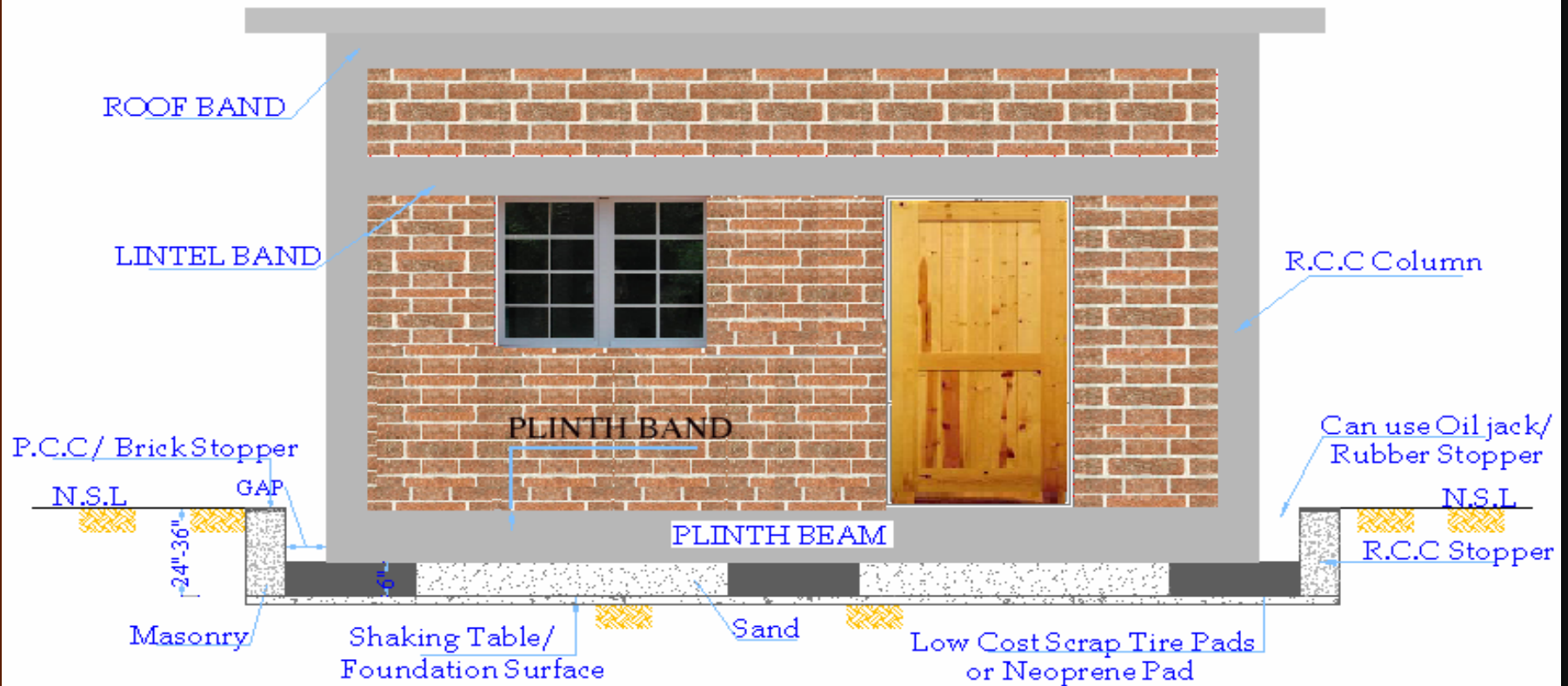

4.1

CROSS SECTION OF STRUCTURE SHOWING DETAILS

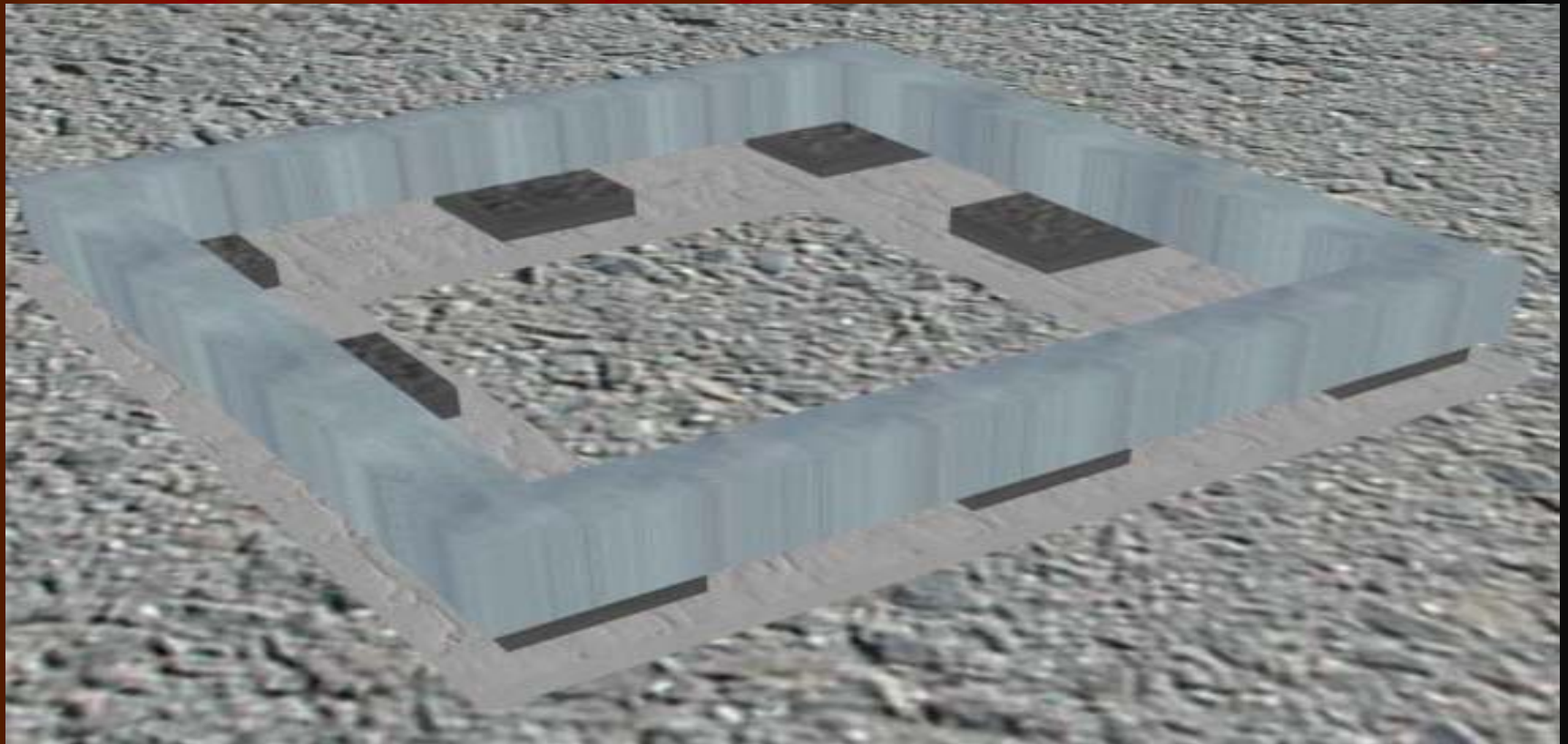

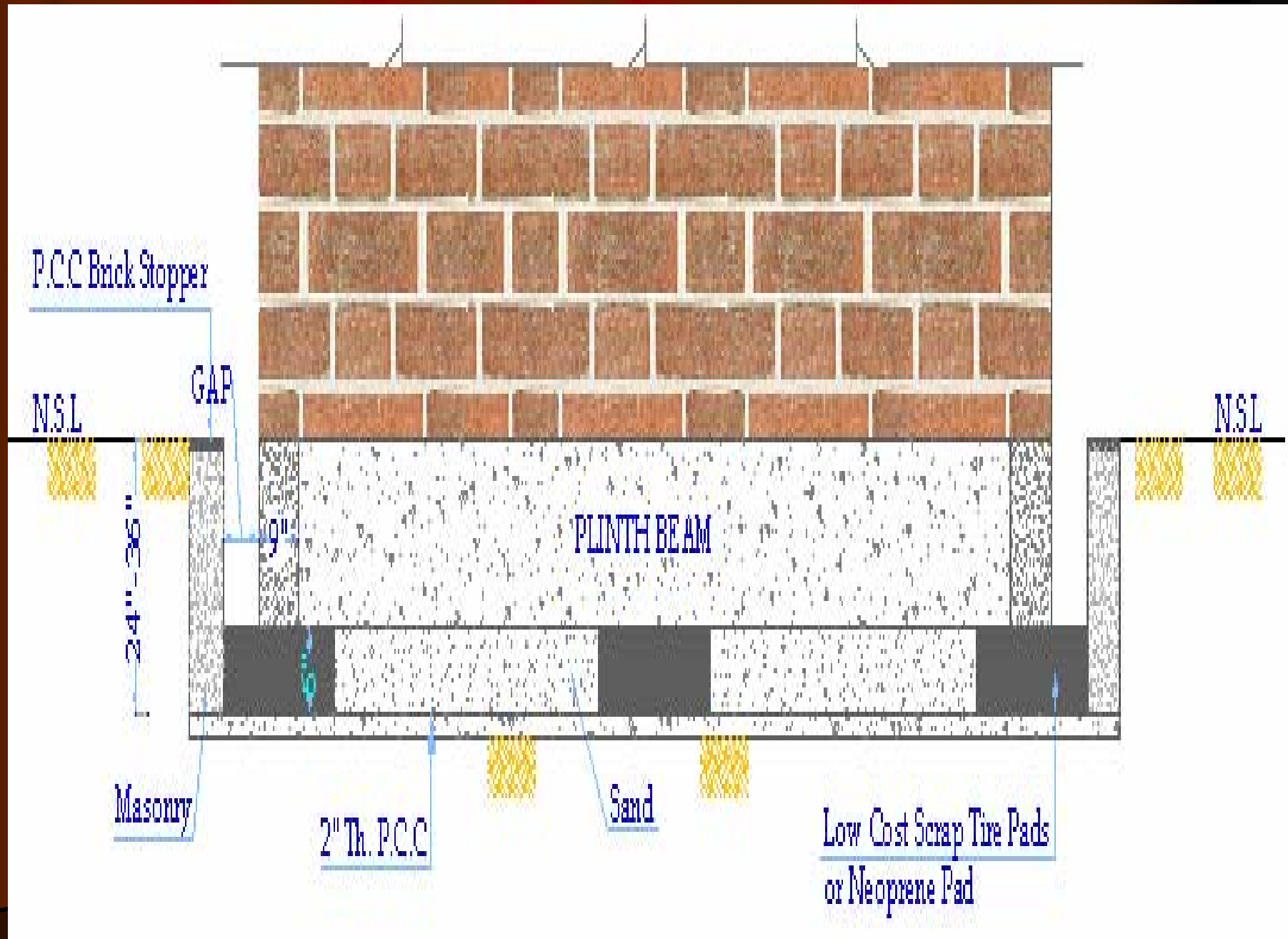

5.0 TESTS ON SHAKING TABLE **FOR PERFORMANCE REVIEW**

THANK YOU